

FPC/FFC 用コネクタ

A18-QAY-0002 rev.1

Connector for FPC/FFC

取り扱い説明書

Manual

適用製品：FPC コネクタ フリップタイプ/ライトアングル接続

Application product: FPC Connector Flip Type/RightAngle

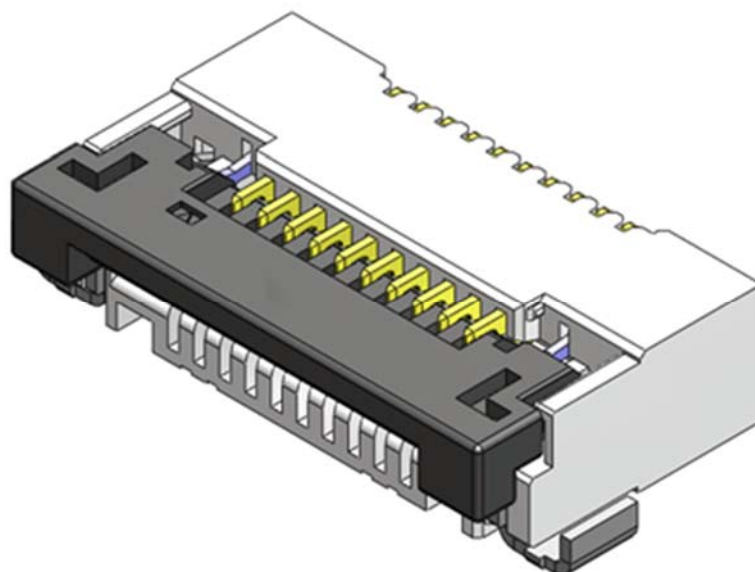

《コネクタの操作方法と注意点 / Operation method and notes of connector》

※図のコネクタの形状は参考とします。

The shape of the connector in the figure is a reference.

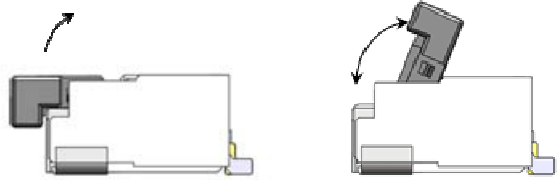
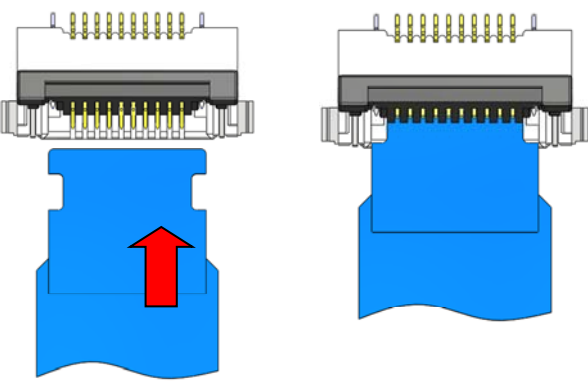
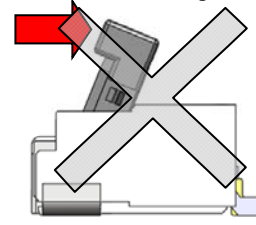
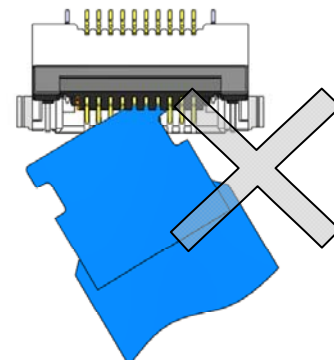
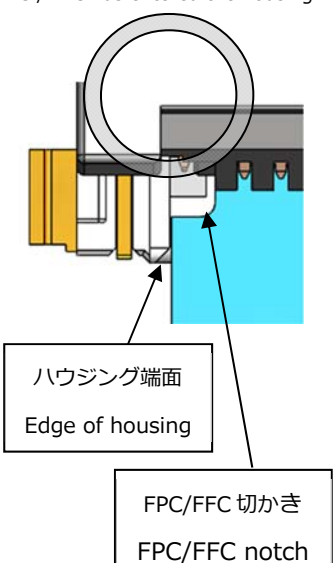
操作方法 / Operation method	使用上の注意点 / Directions point
<p>1.FPC/FFC 挿入方法 FPC/FFC insertion</p> <p>①カバーを上方向に開けて下さい。 (カバーは回転動作をします) pull up the cover to open up. (the cover will rotate to operate)</p>  <p>②FPC/FFC はコジらず、真直ぐ挿入してください。 壁にぶつかる感覚があるまで、押し込んでください。 Please insert FPC/FFC straight. Please push it until it has the sense that runs up against a stone wall.</p> 	<p>カバーに過剰な力を加えないで下さい。変形・破損する事があります。 Do not apply excessive force to the cover. It may be deformed or damaged.</p>  <p>斜めに挿入したり、こじって挿入しますと、半嵌合又は、接点へのダメージの原因となり、接触不良が発生する恐れがございます。 The terminal transformation happens when FPC/FFC is diagonally inserted. And, the loose connection happens.</p>  <p>I-Lock タイプについては、挿入量は FPC/FFC の切かきハウジング内に入り込んだ状態を目安としてください。 For the I-Lock type, please refer to the state where the insertion of the FPC / FFC has entered the housing.</p>  <p>ハウジング端面 Edge of housing</p> <p>FPC/FFC 切かき FPC/FFC notch</p> <p>FPC/FFC 挿入不足 FPC / FFC insertion short</p>

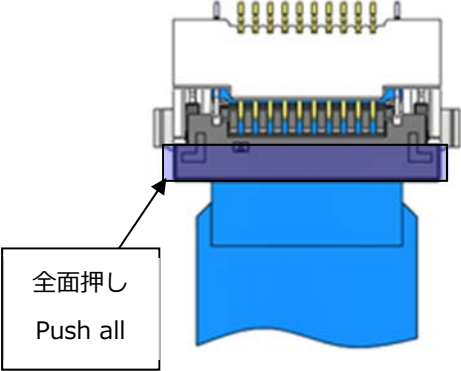
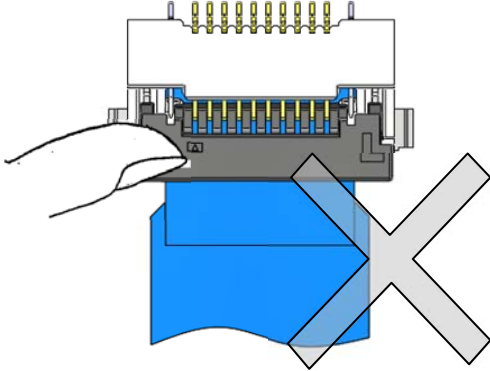
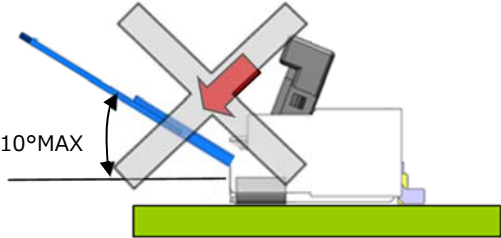
<p>操作方法 Operation method</p>	<p>使用上の注意点 Directions point</p>
<p>2.カバーロック方法 Cover lock</p> <p>①カバーを閉じる際は、できるだけカバーの全面を押してください。 Please push all aspects of the cover when you shut the cover</p> 	<p>多極に於いて両端及び中央のみに強い力を加えると、破損や接触不良の原因となります。カバー全面を押すようにしてください。 If a strong force is applied only to both ends or the center in multipole product, breakage or poor contact It becomes a cause. Please press the entire cover.</p>  <p>FPC・FFCを斜めに挿入した状態でカバーを閉じると、カバーに負荷が掛かり、破損・変形による嵌合不良の原因になります。カバーを閉じる際の挿入角度は10°以下としてください。 When cover is closed with FPC・FFC inserted diagonally, load is applied to the cover, which may cause failure of mating due to breakage or deformation. The insertion angle when closing the cover should be less than 10°.</p> 

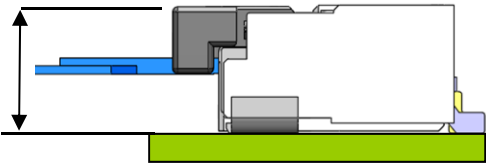
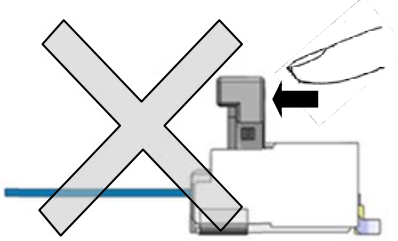
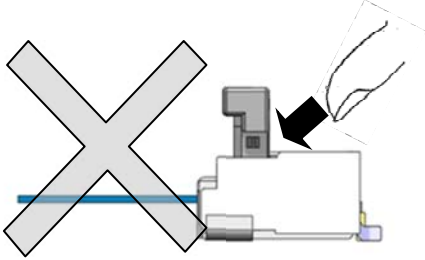
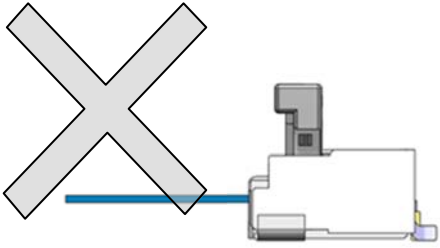
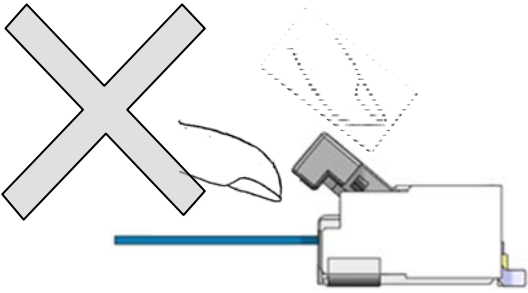
<p style="text-align: center;">操作方法 Operation method</p>	<p style="text-align: center;">使用上の注意点 Directions point</p>
<p>②カバーと基板が平行になるまで、押ししてください。 Please push until the cover becomes parallel to the PCB.</p> 	<p>ロック操作の際に下図の矢印方向に力を加えてカバーを閉めますと、カバー変形の原因になります。 When lock the cover, close the cover with the additional force in arrowhead direction of below figure. It may cause deformation of the cover.</p> <p>FPC/FFCの挿入方向に対し、カバーを強く押し出す様な力を加えて閉じない事。 For insert direction of FPC/FFC, please do not close with additional force strongly pushing cover.</p>  <p>カバーの根元に力を加えて閉じない事。 Please do not close cover with additional force base of cover.</p>  <p>カバーに上から押して閉じない事。 Please do not push the top of cover.</p>  <p>カバーをつまんで引張りながら閉じない事。 Please do not close cover with pinching and pulling.</p> 

操作方法 / Operation method

3. ロック時 Locked

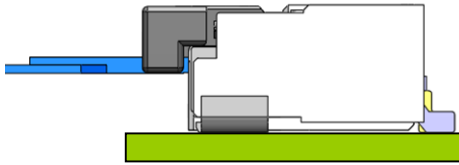

使用上の注意点 / Directions point

FPC/FFC を取りまわす際は、製品に負荷が掛からないように

間口から離れた箇所で取りまわすか、

FPC/FFC に折り曲げ加工を行って下さい。

製品に負荷が掛かるとカバーやハウジング破損の恐れがあります。

When bending the FPC / FFC, bend it at a location away from the opening or process bending the FPC / FFC so that no load is applied to the product. If load is applied to the product, there is a risk of damage to the cover and housing.

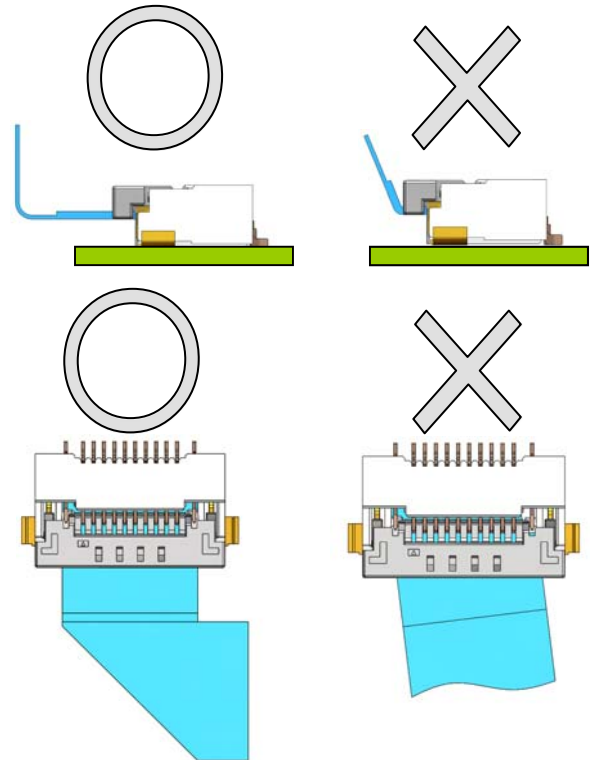

4. FPC/FFC 抜去方法 FPC/FFC extraction

① FPC/FFC 挿入時同様、カバーを上方向へ開けてください。

カバーを操作する際は、両手で操作してください。

(特に多極の場合)

Please open similar and the cover for above when you insert FPC/FFC.

Please operate it by both hands when you operate the cover.

(Especially, for the multipole)

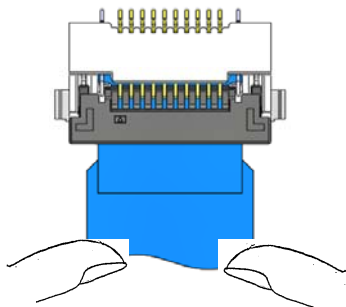

上方向に引抜きますとモールド破損の恐れがありますので、

水平に引き抜いてください。

Pulling it upwards may damage the mold,

so please pull it horizontally.

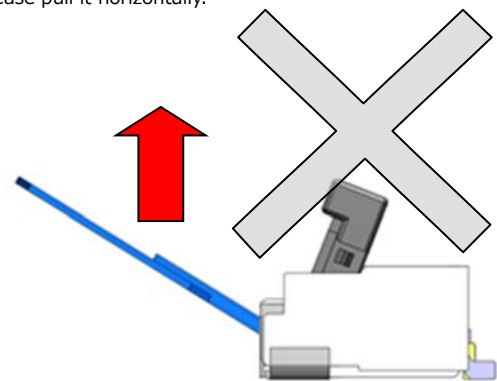

× : 禁止行為 prohibited Operation

その他 Others

①コネクタ実装後、半田接合部が変色する場合がございますが
使用上問題ございません。

There is no problem in use though the solder joint part might discolor
after mounting the connector.

②モールド内に黒点が発生する場合がございますが、性能上
問題ございません。

There is no problem on the performance though the black spot might be
generated in molding.

③リフロー半田付け時、モールドに膨れが発生することが
ございますが、性能上問題ございません。

There is no problem on the performance though the swelling might be
generated in molding when the reflow solder is put up.

④異種金属嵌合は、行わないでください。

Please do not do the different kind metal mating.

⑤カード挿入口前に、カードの姿勢が変わるような部品を
配置しないでください。

Please do not arrange parts into which the posture of the card changes
in the card insertion entrance front.

FPC/FFC 连接器

Connector for FPC/FFC

A18-QAY-0002 rev.1

使用说明书

Manual

适用产品:FPC 连接器 盖帽型/L 型连接

Application product: FPC Connector Flip Type/RightAngle

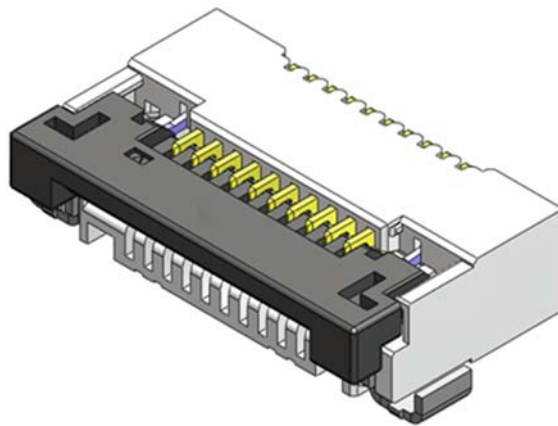

《连接器的操作方法及注意事项/ Operation method and notes of connector》

※视图仅为产品形状的参考。

The shape of the connector in the figure is a reference.

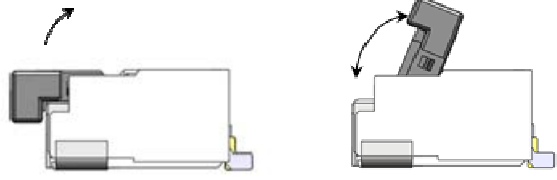
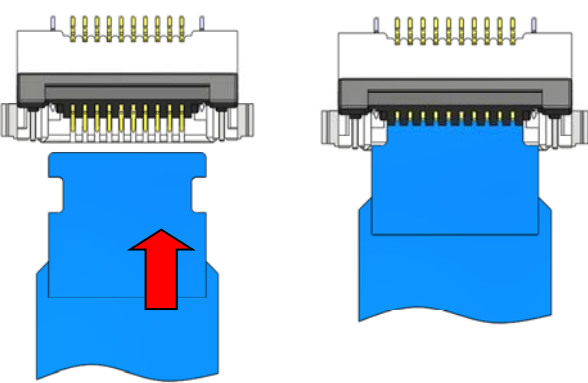
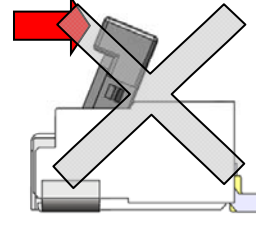
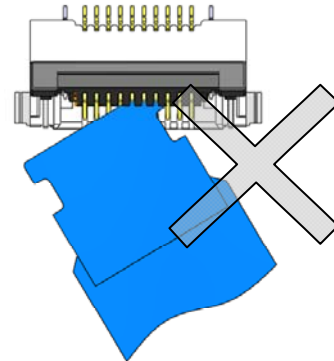
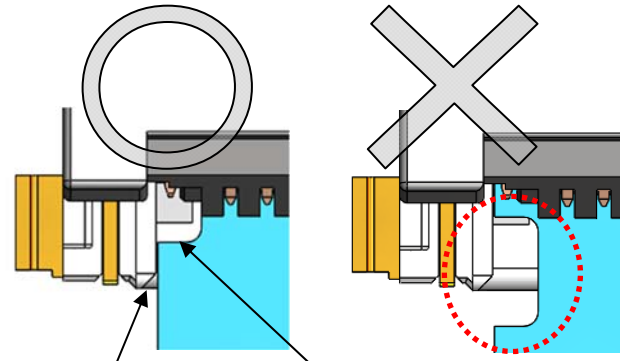
操作方法/Operation method	注意事项/Directions point			
<p>1.FPC/FFC 的插入方法 FPC/FFC insertion</p> <p>①请将盖帽向上翻开（盖帽会转动） pull up the cover to open up. (the cover will rotate to operate)</p>  <p>②请把 FFC/FPC 平顺插入。将 FFC/FPC 前端插入到与壳体底部接触位置。 Please insert FPC/FFC straight. Please push it until it has the sense that runs up against a stone wall.</p> 	<p>禁止翻盖时用力过猛，以免造成盖帽的损坏，变形。 Do not apply excessive force to the cover. It may be deformed or damaged.</p>  <p>斜着插入及扭上劲插接时，容易发生插接不充分及接点的损坏，可能会造成接触不良等。 The terminal transformation happens when FPC/FFC is diagonally inserted. And, the loose connection happens.</p>  <p>I 字型锁紧装置的插入量基准，应将工字缺口插入到壳体内。 For the I-Lock type, please refer to the state where the insertion of the FPC / FFC has entered the housing.</p>  <table border="1" data-bbox="845 1680 1484 1904"> <tr> <td>壳体端面 Edge of housing</td> <td>FPC/FFC 缺口 FPC/FFC notch</td> <td>FPC/FFC 插入不足 FPC / FFC insertion short</td> </tr> </table>	壳体端面 Edge of housing	FPC/FFC 缺口 FPC/FFC notch	FPC/FFC 插入不足 FPC / FFC insertion short
壳体端面 Edge of housing	FPC/FFC 缺口 FPC/FFC notch	FPC/FFC 插入不足 FPC / FFC insertion short		

操作方法/Operation method

注意事项/Directions point

2.盖帽关闭方法 Cover lock

①关闭盖帽时，请尽可能按压盖子的整个表面。

Please push all aspects of the cover when you shut the cover

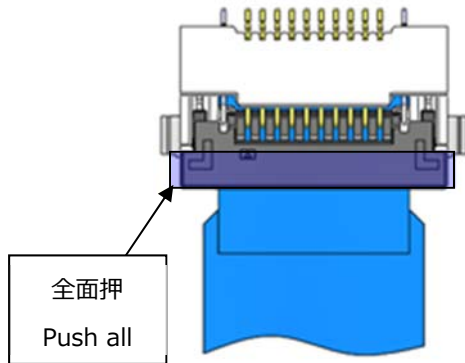

对于大级数连接器，禁止对盖帽的两端或中间位置进行用力关闭作业，会造成破损或接触不良的原因。

If a strong force is applied only to both ends or the center in multipole product, breakage or poor contact It becomes a cause. Please press the entire cover.

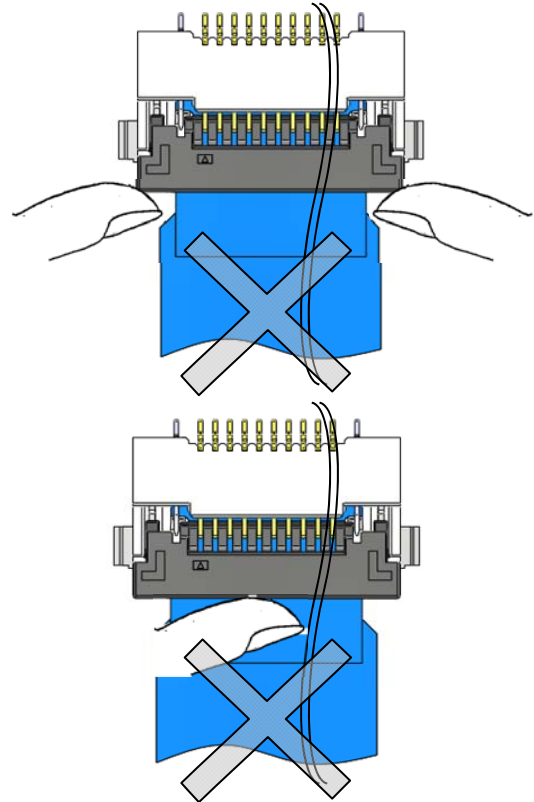

FPC/FFC 斜着插入后关闭盖帽，会使盖帽受到不均的外力，造成盖帽的破损及变形。关闭盖帽时的插入角度要小于 10°。

When cover is closed with FPC · FFC inserted diagonally, load is applied to the cover, which may cause failure of mating due to breakage or deformation.

The insertion angle when closing the cover should be less than 10 °.

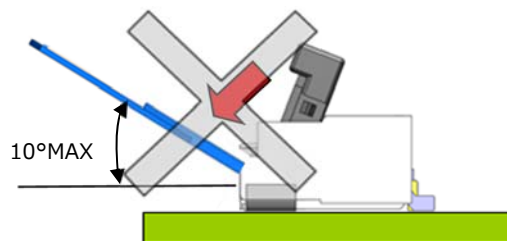

操作方法/Operation method

②将盖帽押回到与电路板平行的位置。

Please push until the cover becomes parallel to the PCB.

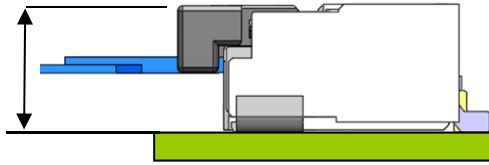

注意事项/Directions point

关闭盖帽时，请勿按下图的箭头方向对盖帽进行操作，以免造成盖帽的变形
When lock the cover, close the cover with the additional force in arrowhead direction of below figure. It may cause deformation of the cover.

禁止在插接 FFC/FPC 的方向，实行关闭盖帽。

For insert direction of FFC/FPC, please do not close with additional force strongly pushing cover.

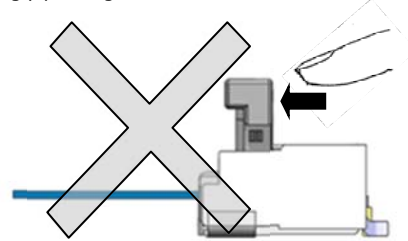

禁止在盖帽回转轴附近负载与盖帽。

Please do not close cover with additional force base of cover.

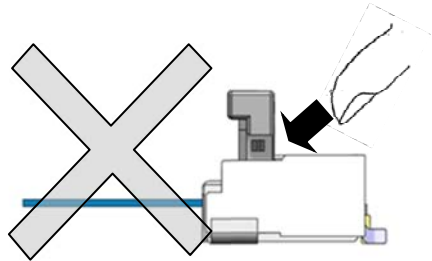

禁止从正上方负载关闭盖帽。

Please do not push the top of cover.

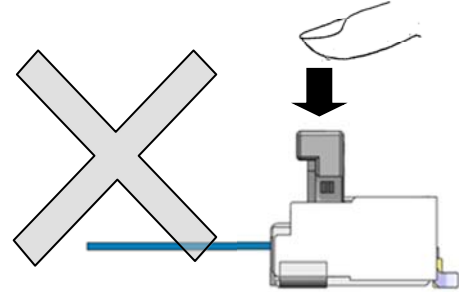

禁止抓住盖帽进行关闭。

Please do not close cover with pinching and pulling.

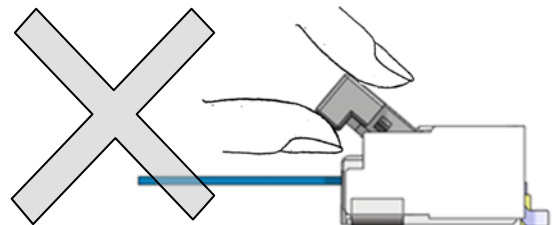

操作方法 / Operation method

注意事项 / Directions point

3. 锁紧时 Locked

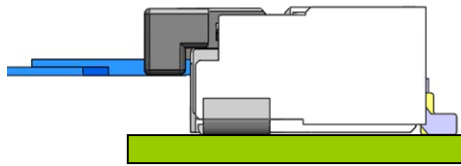

插接好 FFC 后，在固定处理余线部分时，禁止扭上劲固定 FFC。保证接口处留出距离，并进行折角处理后固定。连接器负载会造成盖帽及壳体的损坏。
When bending the FPC / FFC, bend it at a location away from the opening or process bending the FPC / FFC so that no load is applied to the product. If load is applied to the product, there is a risk of damage to the cover and housing.

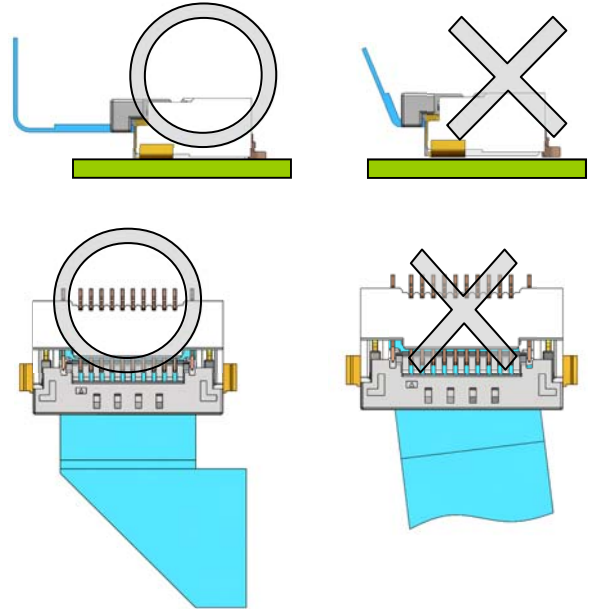

4. 拔取 FPC/FFC 的方法 FPC/FFC extraction

- ① 对接 FPC/FFC 时要打开盖帽后进行。关闭盖帽时要双手作业 (特别是大级数产品)

Please open similar and the cover for above when you insert FPC/FFC.
Please operate it by both hands when you operate the cover.
(Especially, for the multipole)

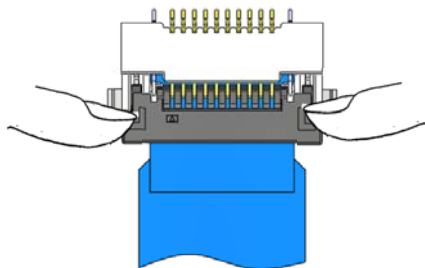

向上受力拔取 FPC/FFC 会造成壳体的损坏。

Pulling it upwards may damage the mold,
so please pull it horizontally.

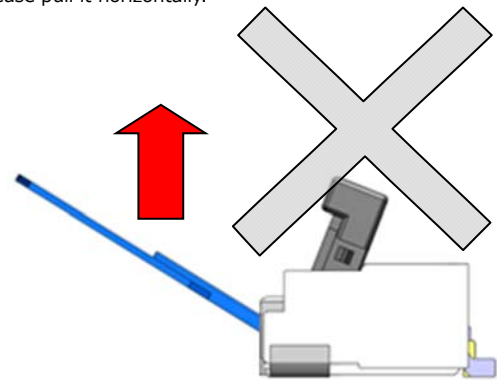

× : 禁止行为 prohibited Operation

补充 Others

① 实装后的连接器焊接部会有变色现象，但不会影响使用。

There is no problem in use though the solder joint part might discolor after mounting the connector.

② 体部会出现黑色斑点，但不会影响产品性能。

There is no problem on the performance though the black spot might be generated in molding.

③ 回流焊接后壳体上可能会出现气泡，但不会影响产品性能。

There is no problem on the performance though the swelling might be generated in molding when the reflow solder is put up.
Please do not do the different kind metal mating.

④ 禁止不同电镀的产品进行对接使用。

⑤ 在产品对接口位置，请勿配置会影响 FFC/FPC 自由状态的零部件。

Please do not arrange parts into which the posture of the card changes in the card insertion entrance front.